



Q7

1U Active Air Cooler

PRODUCT SPECIFICATIONS

Rev 2.0 July 27, 2023

Table of Contents

1. REVISION HISTORY.....	3
2. PRODUCT DESCRIPTION	4
3. THERMAL PERFORMANCE CHART.....	5
4. EP DRAWING	6
5. DM DRAWING	7
6. PRE-PRINTED THERMAL GREASE DIMENSION	8
7. BLOWER SPECIFICATION	9-22
8. RoHS CERTIFICATE	23

Document History List

Rev 2.0, July 27 2023: Update thermal performance

Rev 1.0, Oct.06 2022: Update description of all lead wire color, page 4

Rev 0.0, Sep.30 2022: Initial release

Q7 | Socket LGA1700

Model Number: Q7

- Recommend for Intel® CPU as following
 - Support Intel Core 12th -15th Gen, Socket LGA1700/1851
- Active Air Cooler for 1U Server and Up

Overall Specification

Dimension	95 x 94 x 28.2 mm LWH
Weight	380 g
Material	Copper Vapor Chamber Heatsink with Stacked Fins
Thermal Grease	Shin-Etsu 7762 or Equivalent
TDP	Support CPU 150W at 30°C ambient temperature

Cooling Fan Specification

Model Number	DB128013BU-PWM (Dual-Outlet)
Dimension	φ80 x 13 mm
Bearing	Double Ball
Rated Voltage	12V
Rated Speed	At Duty Cycle 0~20%: 2000± 200 RPM At Duty Cycle 50%: 4900± 10% RPM At Duty Cycle 100%: 8700±10% RPM
Input Power	At Duty Cycle 0~20%: 1.08 W At Duty Cycle 50%: 4.7 W At Duty Cycle 100%: 26.4 W
Maximum Airflow	At Duty Cycle 0~20%: 6.41 CFM At Duty Cycle 50%: 15.26 CFM At Duty Cycle 100%: 26.25 CFM
Rated Static Pressure	At Duty Cycle 0~20%: 3.69 mm-H2O At Duty Cycle 50%: 25.28 mm-H2O At Duty Cycle 100%: 89.80 mm-H2O
Acoustical Noise	At Duty Cycle 0~20%: 23.3 dBA At Duty Cycle 50%: 43.5 dBA At Duty Cycle 100%: 62.2 dBA
Lead Wire Pin Out	Pin#1- Black (-) Pin#2- Black (+) Pin#3- Black (Tachometer/ Signal Output) Pin#4- Black (PWM)

Q7 | Socket LGA1700

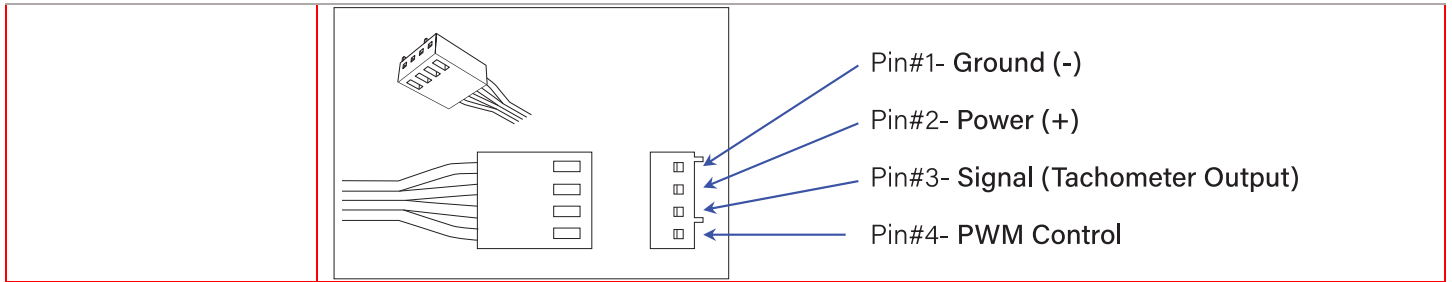

Performance Chart: Active Cooler Q7 Thermal Resistance Thermal Resistance vs. Fan Speed (Duty Cycle and RPM)

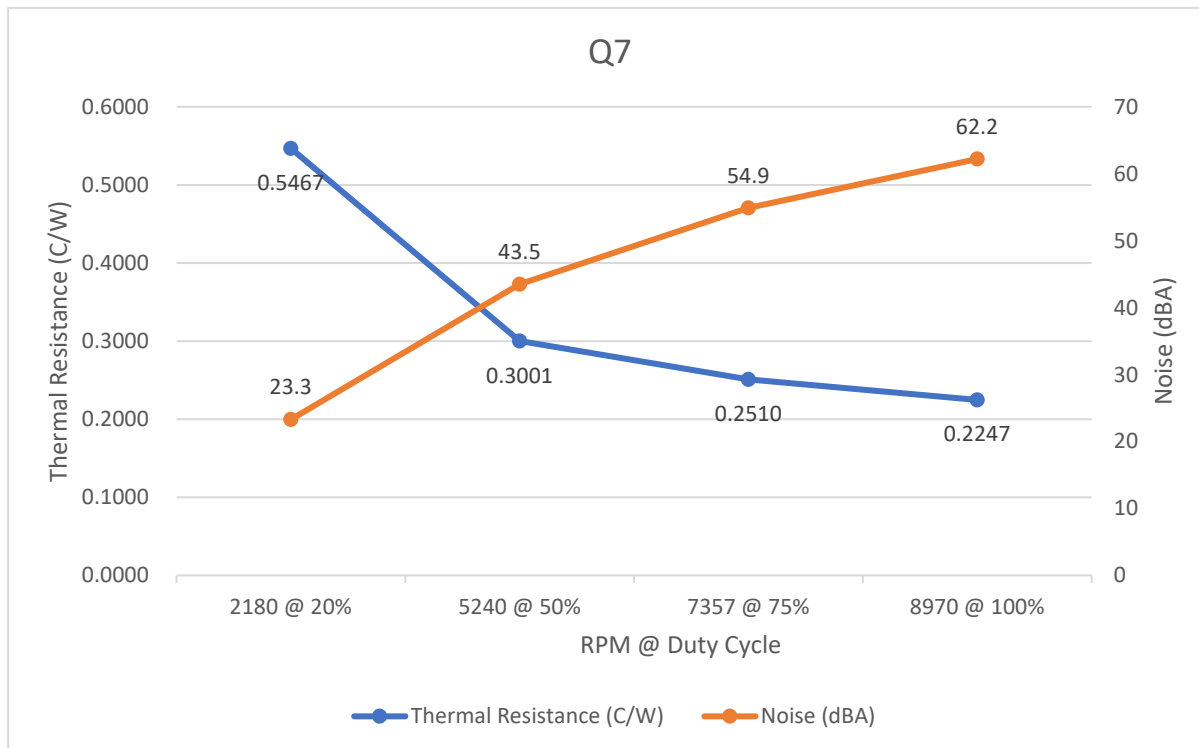

CONFIDENTIAL DOCUMENT

THIS DRAWING CONTAINS INFORMATION PROPRIETARY TO DYNATRON CORPORATION AND DYNAEON INDUSTRIAL CO., LTD. ANY REPRODUCTION, DISCLOSURE, OR USE OF THIS DRAWING IS EXPRESSLY PROHIBITED EXCEPT AS DYNATRON CORPORATION AND DYNAEON INDUSTRIAL CO., LTD. MAY OTHERWISE AGREE TO IN WRITING.

REV#	DESCRIPTION	CHECKER	DATE
0.0	INITIAL RELEASE	LANG	09/30/2022

ASSEMBLY PARTS

WHOLE SET OF HEATSINK

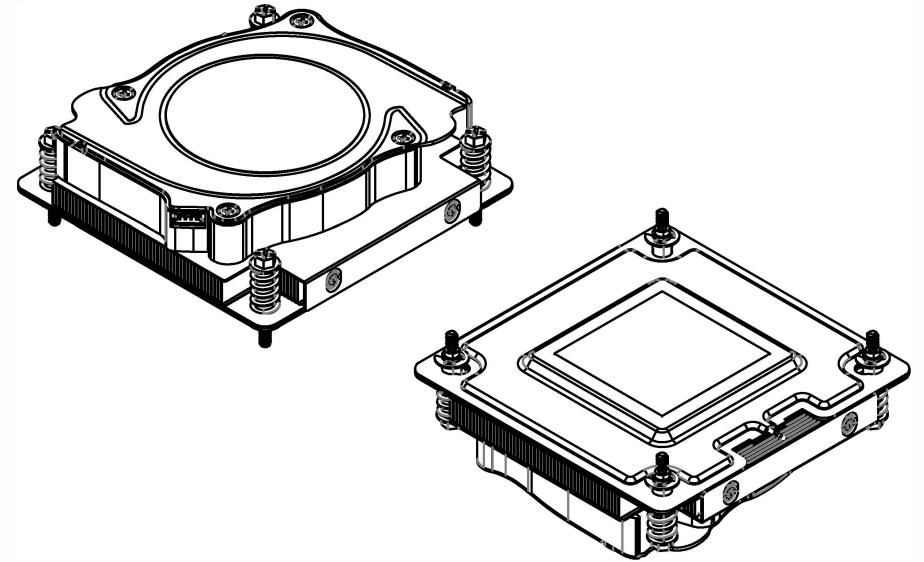
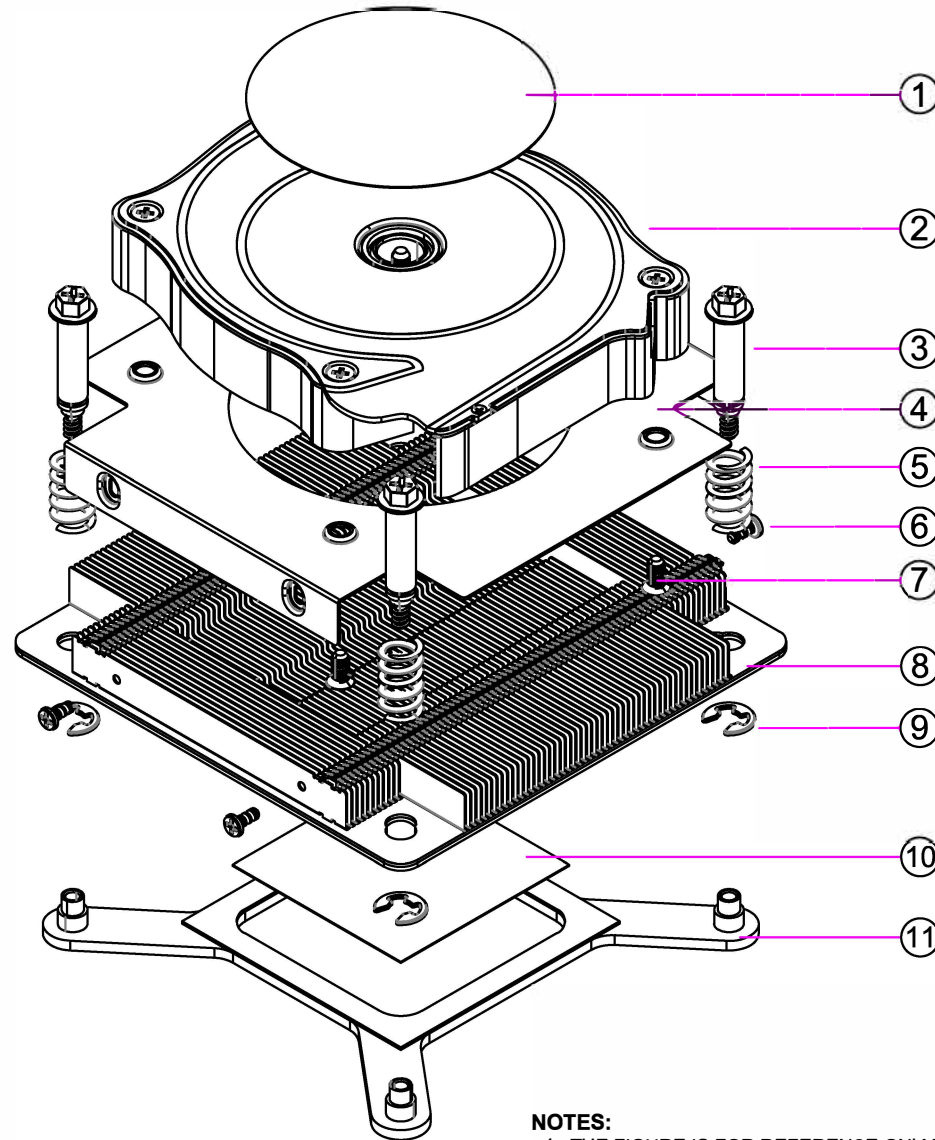

NOTES:

1. THE FIGURE IS FOR REFERENCE ONLY, AND NOT FOR SCALE
2. OVERALL DIMENSION : 95 x 94 x 28.2 mm
3. OVERALL WEIGHT ESTIMATED : 380g

ITEM#	DESCRIPTION	MATERIAL	QTY.
11	BACKPLATE INSULATOR, W / ADHESIVE	SPCC PC	1
10	THERMAL GREASE, PRE-PRINTED	SHIN-ETSU 7762	1
9	C-CLIP	STEEL	4
8	HEATSINK, VAPOR CHAMBER BASE STACKED FIN	COPPER 1100	1
7	SCREW, BLOWER MOUNTING	STEEL	4
6	SCREW, TUNNEL COVER MOUNTING	STEEL	4
5	SPRING (0730)	STEEL	4
4	TUNNEL COVER	METAL	1
3	SCREW (1710)	STEEL	4
2	BLOWER, DUAL-OUTPUT DB128013BU-PWM, 8700 RPM	MOTOR SPCC	1
1	LABEL , BLOWER	PC	1

DATE	NAME	 DYNATRON CORPORATION	
DRAWN 09/30/2022	Engr	TITLE: 1U Active Cooler Model Q7 BOM & Exploded Assembly Drawing	
CHECKED 09/30/2022	LANG		
ENG. APPR.			
MFG. APPR.			
Q.A.			
COMMENTS:		DWG. No:	REV DYN-EP-Q7 0.0

REV#	DESCRIPTION	CHECKER	DATE
0.0	INITIAL RELEASE	LANG	09/30/2022

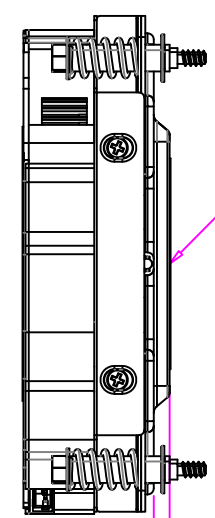
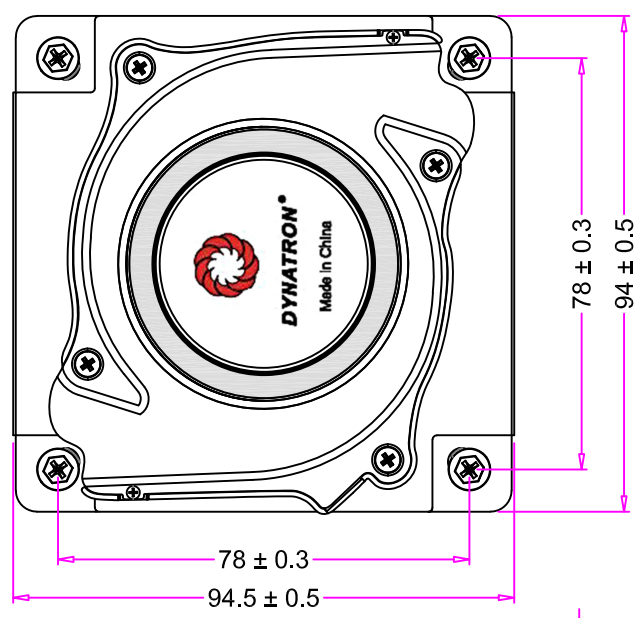
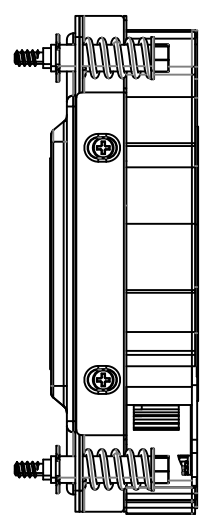
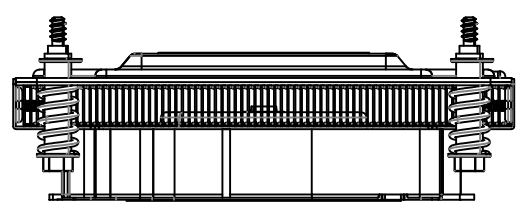

0.10
Ra < 1.2

3.0 +0.2/-0

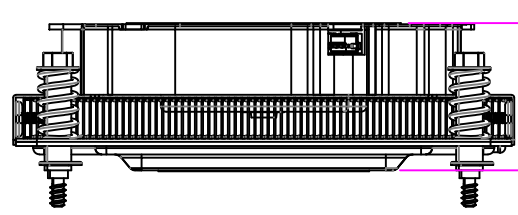

28.2 ± 0.5

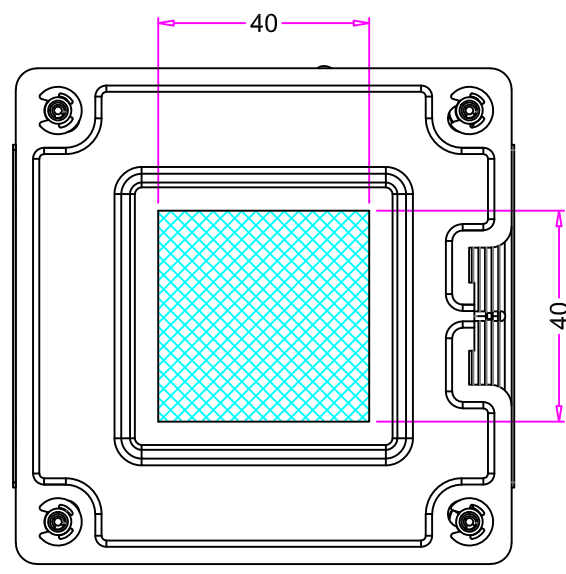

	NAME	DATE
DRAWN BY	ENGR	09/30/2022
CHECKED BY	LANG	09/30/2022
ENG.APPROVED		
MFG.APPROVED	-	-

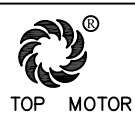

DYNATRON CORPORATION

TOP MOTOR

TITLE: **1U Active Cooler Model Q7**
Overall Dimension Drawing

CONFIDENTIAL DOCUMENT
THIS DRAWING CONTAINS INFORMATION PROPRIETARY TO DYNATRON CORPORATION AND DYNAEON INDUSTRIAL CO., LTD. ANY REPRODUCTION, DISCLOSURE, OR USE OF THIS DRAWING IS EXPRESSLY PROHIBITED EXCEPT AS DYNATRON CORPORATION AND DYNAEON INDUSTRIAL CO., LTD. MAY OTHERWISE AGREE TO IN WRITING.

VIEW		DWG. No:
UNITS	MM	DYN-DM-Q7

REV.	0.0
------	------------

CONFIDENTIAL DOCUMENT

THIS DRAWING CONTAINS INFORMATION PROPRIETARY TO DYNATRON CORPORATION AND DYNAEON INDUSTRIAL CO., LTD. ANY REPRODUCTION, DISCLOSURE, OR USE OF THIS DRAWING IS EXPRESSLY PROHIBITED EXCEPT AS DYNATRON CORPORATION AND DYNAEON INDUSTRIAL CO., LTD. MAY OTHERWISE AGREE TO IN WRITING.

REV #	DESCRIPTION	CHECKER	DATE
0.0	INITIAL RELEASE	LANG	09/30/2022

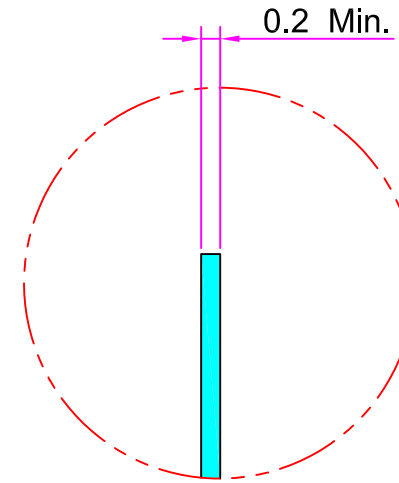
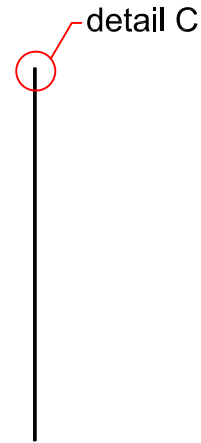
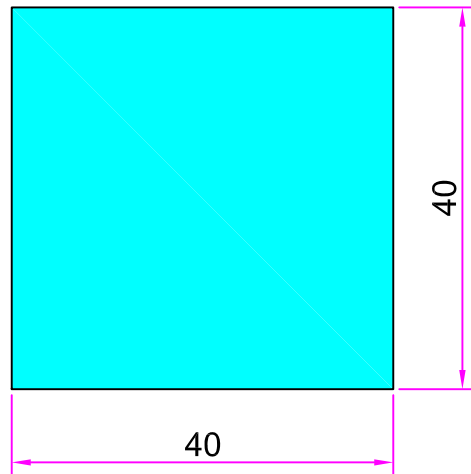

detail C
scale 10 : 1

NOTES:

1. UNIT: MM
2. MATERIAL : SHIN-ETSU 7762 OR EQUIVALENT

	DATE	NAME	 DYNATRON CORPORATION
DRAWN	09/30/2022	enr	
CHECKED	09/30/2022	lang	
ENG. APPR.			
MFG. APPR.			
G.A.			
COMMENTS:			TITLE: Thermal Grease Pre-printed Dimension Drawing
DWG. No:		REV 0.0	



DYNATRON CORPORATION

TOP MOTOR TECHNOLOGY (HUIZHOU) CO, LTD

Specification for Approval

Customer:		
Model Number:	DB128013BU-PWM, DUAL-OUTPUT	
Part Number:		
Issued Date:	Friday, August 19, 2022	
Version:	A	
Customer Approval		
Approval:	Check:	
Corporate Headquarters Dynatron Corporation 33200 Western Avenue Union City, CA 94587 U.S.A. Tel: 510-498-8888 Fax: 510-498-8488	Taipei Office <i>(Taiwan, R.O.C.)</i> 8F, No. 35, Lane:221 Gang Cian. Road, Taipei, Taiwan, R.O.C. Tel: 886-2-27995799 (Rep.) Fax: 886-2-2799-9577	Manufactory TOP MOTOR TECHNOLOGY(HUI ZHOU)CO,LTD Baishi Village, QiuchangTown, Huiyang Dist, HuizhouCity, Guangdong Province, P.R.China Tel: 86-752-822-8000 (Rep.) Fax: 86-752-822-8999
Approval:	Check:	Handler:
Guo xuan		Xiao li



DYNATRON CORPORATION

TOP MOTOR TECHNOLOGY (HUIZHOU) CO, LTD

	CONTENTS	Page
1.	SCOPE	3
2.	ELECTRICAL CHARACTERISTICS	3
3.	MECHANICAL CHARACTERISTICS	4
4.	ENVIRONMENTAL	4
5.	PROTECTION	5
6.	ATTACHMENTS	5
	6.1. Assembly Parts	6
	6.2. Product Dimension	7
	6.3. Frequency Generator Output	8
	6.4. Electrical specifications for PWM production	9-10



DYNATRON CORPORATION

TOP MOTOR TECHNOLOGY (HUIZHOU) CO, LTD

1. SCOPE

This specification defines the electrical and mechanical characteristics of the □ AC / ■ DC Brush less(□Liquid State / ■2-Balls Bearing)axial flow fan, which is carefully designed and manufactured for your special needs by Dynatron Corporation.

2. ELECTRICAL CHARACTERISTICS

Items		Description		
1.	Rated Voltage	DC 12 V		
2.	Operating Voltage	10.8V~13.2V		
3.	PWM Frequency 25KHz	Duty Cycle D=0-20%	Duty Cycle D=50%	Duty Cycle D=100%
4.	Start Voltage	7V		
5.	Air Flow – At rated voltage zero static pressure (minimal value)	0.18 m ³ /z min (6.41CFM)	0.43m ³ /z min (15.26CFM)	0.735m ³ /z min (26.25CFM)
6.	Static Pressure – At rated voltage At zero air flow	3.69mm-H ₂ O (0.145inch-H ₂ O)	25.28mm-H ₂ O (0.992inch-H ₂ O)	89.80mm-H ₂ O (3.53inch-H ₂ O)
7.	Input Current (Max.)	0.09A	0.5A	2.2A
8.	Speed	2000RPM ±200	4900RPM ±10%	8700RPM ±10%
9.	Acoustical Noise	23.3dBA	43.5dBA	62.2dBA
10.	Input Power	1.08W	4.7W	26.4W
11.	Insulation Resistance – Between Frame and Terminal	10 M ohm at DC 500 V		
12.	Dielectric Strength – Between Frame and Terminal	5 mA (Max.) @ AC 500 V 60 Hz 1 min.		
13.	Life – Continuous operating under normal temperature (40 °C or 104 °F)	70,000 hours		
14.	Rotation	Anticlockwise Air Discharged		
15.	Auto restart Time	3-5sec		
16.	Lead Wires	UL 1061, awg 26 or Equivalent “-”: Black; “+”: Black; “S”: Black. “PWM”: Black.		



DYNATRON CORPORATION

TOP MOTOR TECHNOLOGY (HUIZHOU) CO, LTD

3. MECHANICAL CHARACTERISTICS

Items		Description
1.	Dimension	Display as Drawing
2.	Frame	PPS UL94V-0 (Black)
3.	Impeller	PBT UL94V-0 (Black)
4.	Bearing System	Two balls Bearing
5.	Weight	6 0 grams

4. ENVIRONMENTAL

Items		Description
1.	Operating Temperature	- 10 °C ~ + 65 °C (65 %RH)
2.	Storage Temperature	- 30 °C ~ + 70 °C (65 %RH)
3.	Vibration Test	Motor withstands 1000 rpm vibrating with 2 mm amplitude for 30 minutes up and down, right and left, back and forth directions.
4.	Drop Test	Motor withstands one free body drop from 30 cm in high onto 10 mm thickness of wooden board for each of the three faces in minimum packing condition.
5.	Acoustic Noise	62.20dBA – Curve (Max62.70dBA) Measuring Condition – Under rated voltage in semi-anechoic chamber equipment sound level meter. (Figure A.)

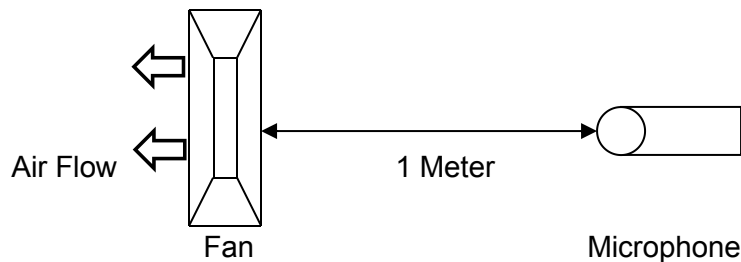

Figure A – Noise Level is measure at rated voltage in anechoic chamber in free air as above.



DYNATRON CORPORATION

TOP MOTOR TECHNOLOGY (HUIZHOU) CO, LTD

5. PROTECTION

Items		Description
1.	Polarity Protection	For polarity error connection to power, the circuit withstands reversed connection between positive and negative leads.

6. ATTACHMENTS

- 6.1. Assembly Parts
- 6.2. Product Dimension
- 6.3. Frequency Generator Output
- 6.4. Electrical specifications for pwm production



DYNATRON CORPORATION

TOP MOTOR TECHNOLOGY (HUIZHOU) CO, LTD

6.1. Product Dimension

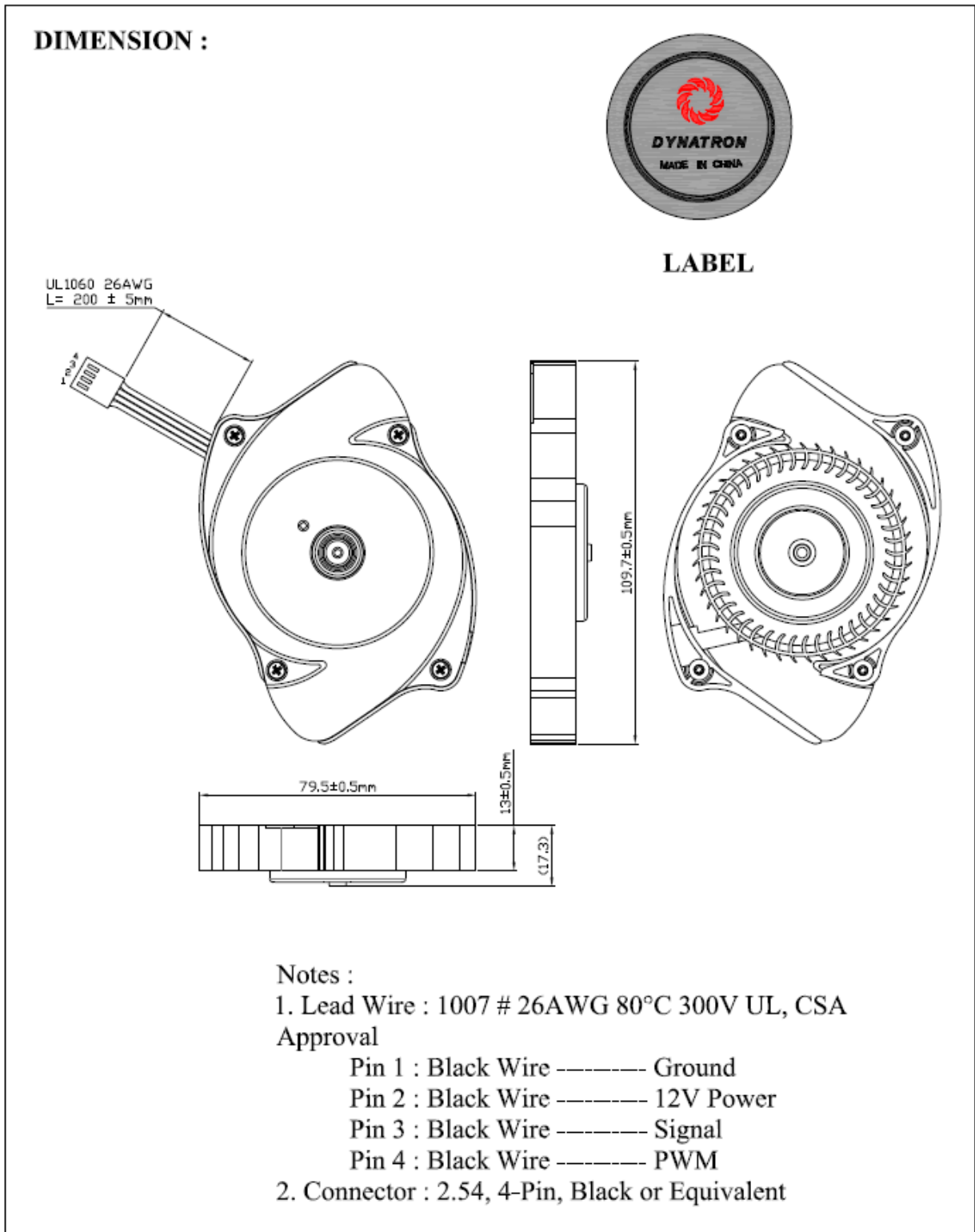



DYNATRON CORPORATION

TOP MOTOR TECHNOLOGY (HUIZHOU) CO, LTD

6.2. Frequency Generator Output

FREQUENCY GENERATOR O/P:

Frequency generator function is activated by an internal IC for customer's application.
Electrical schematic:

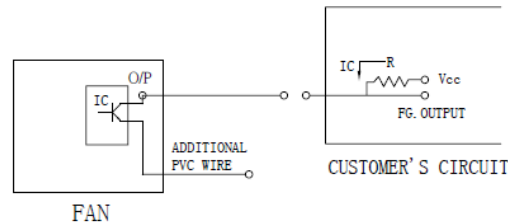

CUSTOMER'S CIRCUIT

V_{cc} = From +5 To +28 VDC (Generally using +12 or +24 VDC)

I_c = 5 mA max.

$R = V/I$ (Output "R" value calculation)

● SUPPLY A WAVEFORM:

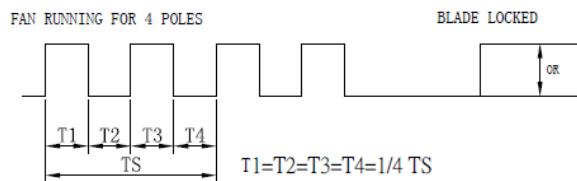

$N = R.P.M.$ (Rotation speed will be different for various models
L/M/H/HH/VH/SH)

$TS = 60/N$ (Sec)

* Voltage level after blade locked

● OUTPUT LEVEL:

High = V_{cc} 10%

Low = 0~0.5V

I_c = 5 mA max.

● APPLICATION:

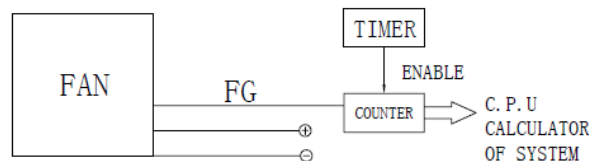

● FUNCTIONS:

- By means of waveform & customer's design, schematic can reach alarm function, either in the form of buzzing or LED flashing. Adjust rotation speed.
- When power supply output voltage level decreases, it will result in the lowering of fan rotation speed. The irregular situation will be controlled by using FG. O/P through P/S circuit to increase the output voltage and result in a stable rotation speed.



DYNATRON CORPORATION

TOP MOTOR TECHNOLOGY (HUIZHOU) CO, LTD

6.3. TUV Certificate

Zertifikat

Certificate



Zertifikat Nr. Certificate No. R 50064443
Blatt Page 0002

Ihr Zeichen Client Reference PC/DTI
Unser Zeichen Our Reference ZTW1-TCC- 10013649 002
Ausstellungsdatum Date of Issue 11.11.2005 (day/mo/yr)

Genehmigungsinhaber License Holder
Dynacon Industrial Co., Ltd.
1st Fl., No. 362, Tanan Rd.
Taipei 111
Taiwan, R.O.C.

Fertigungsstätte Manufacturing Plant
Dynacon Ind. Co., Ltd.
Ta-Li Management Zone
Ching-Hsi, Dongguan
P.R. China

Prüfzeichen Test Mark
Geprüft nach Tested acc. to
EN 60950-1:2001+A11



Zertifiziertes Produkt (Geräteidentifikation)
Certified Product (Product Identification)

Lizenzentgelte - Einheit
License Fee - Unit

Ventilator (DC Fan)

wie Blatt (as page) 01

Ergänzung (Addition)

Bezeichnung : DF(X1)(X2)(X3)(X4)(X5)ZZZZ-(X6)
(Type Designation)
(X1) steht für (stands for) : 05, 12, 24
(X2) steht für (stands for) : 40, 50, 60, 70, 80
(X3) steht für (stands for) : 10, 15, 20
(X4) steht für (stands for) : S, B, P, Q
(X5) steht für (stands for) : U, H, M, L, E
Z steht für (stands for) : A-Z, 0-9 oder freibleibend
(or blank)

(X6) steht für (stands for) : A, B
Nennspannung : DC 5V (X1 = 05); DC 12V (X1 = 12)
(Rated Voltage) DC 24V (X1 = 24)
Nennstrom : siehe Aufbau-Übersicht
(Rated Current) (see constructional dataform)



ANLAGE (Appendix): 1.1

Dem Zertifikat liegt unsere Prüf- und Zertifizierungsordnung zugrunde.
Das Produkt entspricht den o.g. Anforderungen, die Herstellung wird überwacht.
This certificate is based on our Testing and Certification Regulation. The product fulfills above-mentioned-requirements, the production is subject to surveillance.

Zertifizierungsstelle

TÜV Rheinland Product Safety GmbH, Am Grauen Stein, D-51105 Köln

Tel.:(+49/221)8 06 - 13 71 Fax:(+49/221)8 06 - 39 35 e-mail: Althoff@de.tuv.com

Dipl.-Ing. F. Stöckel



DYNATRON CORPORATION

TOP MOTOR TECHNOLOGY (HUIZHOU) CO, LTD

6.4. UL Certificate



ONLINE CERTIFICATIONS DIRECTORY

GPWV2.E157868 Fans, Electric - Component

[Page Bottom](#)

Fans, Electric - Component

[See General Information for Fans, Electric - Component](#)

DYNAEON INDUSTRIAL CO LTD
8TH FL 35 LANE 221 GANGCIAN RD
NEIHU DIST
TAIPEI, 114 TAIWAN

E157868

DC fans, Models D(F)1206(Z)(Y1)(X1), D(F)1207(Z)(Y1)(X1), where (F) may be F or C, (Z) may be SH, BH, BA, SM, BM, BB, SL, BL, BC, SD, BE, BF, SG, BI, BJ, SK, BN, BO, SP, BQ, BR, SS, BT, BU, SV, BW, BX, SY, BY or BZ, (Y1) may be "-", 0 through 9 or A through Z, (X1) may be 0 through 9 or A through Z.

Models DF248015(S)(X)(Y)(Z)(W), DF488015(S)(X)(Y)(Z)(W), where (S) may be S, B or P, (X) may be U, H, M or L, (Y) and (Z) may be any alphanumeric character, blank, "-" or any symbol, (W) may be seven any alphanumeric character, blank, "-" or any symbol.

Models DF121225(A)(B)(C), DF121225(A)E(C), DF241225(A)(B)(C), DF128015(A)U(C), DF128015(A)(B)(C), DF128025(A)U(C), DF128025(A)(B)(C), DF128025(A)E(C), DF248025(A)U(C), DF248025(A)(B)(C), DF129225(A)(B)(C), DF129225(A)E(C), DF249225(A)U(C), DF249225(A)(B)(C), DF126010(A)(B)(C), DF246025(A)U(C), DF246025(A)(B)(C), DF126025(A)U(C), DF126025(A)(B)(C), DF126025(A)E(C), DB126015BU(C), DB126015B(B)(C), DF123010(A)(B)(C), DF053010(A)(B)(C), DF127015(A)U(C), DF127015(A)(B)(C), DF245010(A)(B)(C), where (A) may be S, B, P or Q, (B) may be H, M or L, (C) may be xxxxxxxx, where x may be A through Z, 0 through 9, "-" or blank.

Models DF122510(X)(Y2)(Z)-(M), DF124020(X)(Y2)(Z)-(M), DF244020(X)(Y1)(Z)-(M), DF126025(X)(Y3)(Z)-(M), DF246025(X)(Y3)(Z)-(M), DF121225(X)(Y1)(Z)-(M), DF124028(X)(Y3)(Z)-(M), where (X) may be S, B, P, Q, (Y1) may be H, M or L, (Y2) may be U, H, M or L, (Y3) may be U, H, M, L or E, (Z) is alphanumeric combination of five digits and/or alphabets, may be A through Z, 0 through 9 or blank, (M) may be A or B.

Models DF054010(X)(Y2)(Z1)(Z2)-A, DF054010(X)L(Z1)(Z2)-B, DF124010(X)(Y2)(Z1)(Z2)-A, DF124010(X)L(Z1)(Z2)-B, DF244010(X)(Y2)(Z1)(Z2)-A, DF125015(X)(Y1)(Z1)(Z2)-A, DF125020(X)(Y3)(Z1)(Z2)-A, DF126015(X)(Y1)(Z1)(Z2)-A, DF246015(X)M(Z1)(Z2)-A, DF246015(X)L(Z1)(Z2)-A, DF128020(X)(Y1)(Z1)(Z2)-A, DF128020(X)L(Z1)(Z2)-B, DB127015(X)(Y2)(Z)-A series, where (X) may be S, B, P, Q, (Y1) may be H, M or L, (Y2) may be U, H, M or L, (Y3) may be H, M, L or E, (Z1) may be blank or 3, (Z2) is alphanumeric combination of four digits and/or alphabets, may be A through Z, 0 through 9 or blank, (Z) is alphanumeric combination of five digits and/or alphabets, may be A through Z, 0 through 9 or blank.

Models DF125010(X)(Y)(Z)-A, DF126020(X)(Y)(Z)-A, DF246020(X)(Y)(Z)-A, DF121525(X)(Y1)(Z)-A, DF121525(X)(Y2)(Z)-B series, Where (X) may be S, B, P or Q, (Y) may be H, M or L, (Y1) may be U, H or M, (Y2) may be L or E, (Z) is alphanumeric combination of five digits and/or alphabets, may be A through Z, 0 through 9 or blank.

Models DF128025(X)(a)(Y)-A, DF121225(X)(b)(Y)-C, DF121225(X)E(Y)-C, DF127720(X)(a)(Y)-A, DF121425(X)(c)(Y)-A, DF126010(X)E(Y)-A series, where (X) may be S, B, P, Q, (a) may be H, M, L or E, (b) may be M or L, (c) may be U, H, M, L or E, (Y) is alphanumeric combination of five digits and/or alphabets, may be A through Z, 0 through 9 or blank.

Models DF054010(X)(Y1)(Z1)(Z2)-C, DF124010(X)(Y2)(Z1)(Z2)-C, DF244010(X)(Y2)(Z1)(Z2)-C, DF124020BU(Z1)(Z2)-C, DF124020(X)(Y1)(Z1)(Z2)-C, DF124028BU(Z1)(Z2)-C, DF124028(X)(Y1)(Z1)(Z2)-C, DF126025BU(Z1)(Z2)-C, DF126025(X)(Y1)(Z1)(Z2)-C, DF127015BU(Z1)(Z2)-A, DF127015(X)(Y1)(Z1)(Z2)-A, DF128025BU(Z1)(Z2)-B, DF128025(X)(Y1)(Z1)(Z2)-B, DF129225BU(Z1)(Z2)-A, DF129225(X)(Y1)(Z1)(Z2)-A, DF121225BU(Z1)(Z2)-D, DF121225(X)(Y1)(Z1)(Z2)-D, DF121425(X)(Y1)(Z1)(Z2)-B, DB127015BU(Z1)(Z2)-B, DB127015(X)(Y1)(Z1)(Z2)-B, DB058015(X)(Y3)(Z1)(Z2)-A, where (X) may be S, B, P or Q, where (Y1) may be H, M, L or E, where (Y2) may be U, H, M, L or E, where (Y3) may be M or L, where (Z1) may be blank or 3, where (Z2) may be is alphanumeric combination of four digits and/or alphabets, may be A through Z, 0 through 9 or blank.

Models DB128015(X)(Y1)-(Z)-A, DF128038(X)(Y1)-(Z)-A, DB121225(X)(Y2)-(Z)-A, DF054010(X)(Y2)-(Z)-D, DF124010(X)(Y3)-(Z)-D, DF244010(X)(Y4)-(Z)-D, DF125010(X)(Y2)-(Z)-B, DF126010(X)(Y5)-(Z)-B series, where (X) may be S, B, P, Q, (Y1) may be U, H, M, L or E, (Y2) may be H, M or L, (Y3) may be U, M, L or E, (Y4) may be U, H, M or L, (Y5) may be H, M, L or E, (Z) is alphanumeric combination of five digits and/or alphabets, may be A through Z, 0 through 9 or blank.

Electric fans, Models DC0504, -1204, -1205, -1206, DF1204, -1208, -2408, -0504, -0505, -1205, -2406 followed by "S" or



DYNATRON CORPORATION

TOP MOTOR TECHNOLOGY (HUIZHOU) CO, LTD

"B", followed by two alphanumeric characters.

Low voltage fans, Models DB1206, DF1209, -1212, -2409, DH1204 followed by B or S, followed by two alphanumeric characters.



Marking: Company name or trademark **TOP MOTOR**, model designation and Recognized Component Mark for Canada,



Last Updated on 2008-02-18

[Questions?](#)

[Notice of Disclaimer](#)

[Page Top](#)

Copyright © 2009 Underwriters Laboratories Inc.®

The appearance of a company's name or product in this database does not in itself assure that products so identified have been manufactured under UL's Follow-Up Service. Only those products bearing the UL Mark should be considered to be Listed and covered under UL's Follow-Up Service. Always look for the Mark on the product.

UL permits the reproduction of the material contained in the Online Certification Directory subject to the following conditions: 1. The Guide Information, Designs and/or Listings (files) must be presented in their entirety and in a non-misleading manner, without any manipulation of the data (or drawings). 2. The statement "Reprinted from the Online Certifications Directory with permission from Underwriters Laboratories Inc." must appear adjacent to the extracted material. In addition, the reprinted material must include a copyright notice in the following format: "Copyright © 2009 Underwriters Laboratories Inc.®"

An independent organization working for a safer world with integrity, precision and knowledge.





DYNATRON CORPORATION

TOP MOTOR TECHNOLOGY (HUIZHOU) CO, LTD

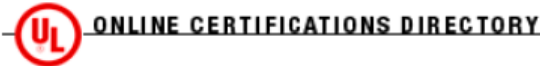

GPWV8.E157868

Fans, Electric Certified for Canada - Component

[Page Bottom](#)

Fans, Electric Certified for Canada - Component

[See General Information for Fans, Electric Certified for Canada - Component](#)

DYNAEON INDUSTRIAL CO LTD
8TH FL 35 LANE 221 GANGCIAN RD
NEIHU DIST
TAIPEI, 114 TAIWAN

E157868

DC fans, Models D(F)1206(Z)(Y1)(X1), D(F)1207(Z)(Y1)(X1), where (F) may be F or C, (Z) may be SH, BH, BA, SM, BM, BB, SL, BL, BC, SD, BE, BF, SG, BI, BJ, SK, BN, BO, SP, BQ, BR, SS, BT, BU, SV, BW, BX, SY, BY or BZ, (Y1) may be "-", 0 through 9 or A through Z, (X1) may be 0 through 9 or A through Z.

Models DF248015(S)(X)(Y)(Z)(W), DF488015(S)(X)(Y)(Z)(W), where (S) may be S, B or P, (X) may be U, H, M or L, (Y) and (Z) may be any alphanumeric character, blank, "-" or any symbol, (W) may be seven any alphanumeric character, blank, "-" or any symbol.

Models DF121225(A)(B)(C), DF121225(A)E(C), DF241225(A)(B)(C), DF128015(A)U(C), DF128015(A)(B)(C), DF128025(A)U(C), DF128025(A)(B)(C), DF128025(A)E(C), DF248025(A)U(C), DF248025(A)(B)(C), DF129225(A)(B)(C), DF129225(A)E(C), DF249225(A)U(C), DF249225(A)(B)(C), DF126010(A)(B)(C), DF246025(A)U(C), DF246025(A)(B)(C), DF126025(A)U(C), DF126025(A)(B)(C), DF126025(A)E(C), DB126015BU(C), DB126015B(B)(C), DF123010(A)(B)(C), DF053010(A)(B)(C), DF127015(A)U(C), DF127015(A)(B)(C), DF245010(A)(B)(C), where (A) may be S, B, P or Q, (B) may be H, M or L, (C) may be xxxxxxxx, where x may be A through Z, 0 through 9, "-" or blank.

Models DF122510(X)(Y2)(Z)-(M), DF124020(X)(Y2)(Z)-(M), DF244020(X)(Y1)(Z)-(M), DF126025(X)(Y3)(Z)-(M), DF246025(X)(Y3)(Z)-(M), DF121225(X)(Y1)(Z)-(M), DF124028(X)(Y3)(Z)-(M), where (X) may be S, B, P, Q, (Y1) may be H, M or L, (Y2) may be U, H, M or L, (Y3) may be U, H, M, L or E, (Z) is alphanumeric combination of five digits and/or alphabets, may be A through Z, 0 through 9 or blank, (M) may be A or B.

Models DF054010(X)(Y2)(Z1)(Z2)-A, DF054010(X)L(Z1)(Z2)-B, DF124010(X)(Y2)(Z1)(Z2)-A, DF124010(X)L(Z1)(Z2)-B, DF244010(X)(Y2)(Z1)(Z2)-A, DF125015(X)(Y1)(Z1)(Z2)-A, DF125020(X)(Y3)(Z1)(Z2)-A, DF126015(X)(Y1)(Z1)(Z2)-A, DF246015(X)M(Z1)(Z2)-A, DF246015(X)L(Z1)(Z2)-A, DF128020(X)(Y1)(Z1)(Z2)-A, DF128020(X)L(Z1)(Z2)-B, DB127015(X)(Y2)(Z)-A series, where (X) may be S, B, P, Q, (Y1) may be H, M or L, (Y2) may be U, H, M or L, (Y3) may be H, M, L or E, (Z1) may be blank or 3, (Z2) is alphanumeric combination of four digits and/or alphabets, may be A through Z, 0 through 9 or blank, (Z) is alphanumeric combination of five digits and/or alphabets, may be A through Z, 0 through 9 or blank.

Models DF125010(X)(Y)(Z)-A, DF126020(X)(Y)(Z)-A, DF246020(X)(Y)(Z)-A, DF121525(X)(Y1)(Z)-A, DF121525(X)(Y2)(Z)-B series, Where (X) may be S, B, P or Q, (Y) may be H, M or L, (Y1) may be U, H or M, (Y2) may be L or E, (Z) is alphanumeric combination of five digits and/or alphabets, may be A through Z, 0 through 9 or blank.

Models DF128025(X)(a)(Y)-A, DF121225(X)(b)(Y)-C, DF121225(X)E(Y)-C, DF127720(X)(a)(Y)-A, DF121425(X)(c)(Y)-A, DF126010(X)E(Y)-A series, where (X) may be S, B, P, Q, (a) may be H, M, L or E, (b) may be M or L, (c) may be U, H, M, L or E, (Y) is alphanumeric combination of five digits and/or alphabets, may be A through Z, 0 through 9 or blank.

Models DF054010(X)(Y1)(Z1)(Z2)-C, DF124010(X)(Y2)(Z1)(Z2)-C, DF244010(X)(Y2)(Z1)(Z2)-C, DF124020BU(Z1)(Z2)-C, DF124020(X)(Y1)(Z1)(Z2)-C, DF124028BU(Z1)(Z2)-C, DF124028(X)(Y1)(Z1)(Z2)-C, DF126025BU(Z1)(Z2)-C, DF126025(X)(Y1)(Z1)(Z2)-C, DF127015BU(Z1)(Z2)-A, DF127015(X)(Y1)(Z1)(Z2)-A, DF128025BU(Z1)(Z2)-B, DF128025(X)(Y1)(Z1)(Z2)-B, DF129225BU(Z1)(Z2)-A, DF129225(X)(Y1)(Z1)(Z2)-A, DF121225BU(Z1)(Z2)-D, DF121225(X)(Y1)(Z1)(Z2)-D, DF121425(X)(Y1)(Z1)(Z2)-B, DB127015BU(Z1)(Z2)-B, DB127015(X)(Y1)(Z1)(Z2)-B, DB058015(X)(Y3)(Z1)(Z2)-A, where (X) may be S, B, P or Q, where (Y1) may be H, M, L or E, where (Y2) may be U, H, M, L or E, where (Y3) may be M or L, where (Z1) may be blank or 3, where (Z2) may be is alphanumeric combination of four digits and/or alphabets, may be A through Z, 0 through 9 or blank.

Models DB128015(X)(Y1)-(Z)-A, DF128038(X)(Y1)-(Z)-A, DB121225(X)(Y2)-(Z)-A, DF054010(X)(Y2)-(Z)-D, DF124010(X)(Y3)-(Z)-D, DF244010(X)(Y4)-(Z)-D, DF125010(X)(Y2)-(Z)-B, DF126010(X)(Y5)-(Z)-B series, where (X) may be S, B, P, Q, (Y1) may be U, H, M, L or E, (Y2) may be H, M or L, (Y3) may be U, M, L or E, (Y4) may be U, H, M or L, (Y5) may be H, M, L or E, (Z) is alphanumeric combination of five digits and/or alphabets, may be A through Z, 0 through 9 or blank.

Electric fans, Models DC0504, -1204, -1205, -1206, DF0504, -0505, -1204, -1205, -1208, -2406, -2408 followed by "S" or



DYNATRON CORPORATION

TOP MOTOR TECHNOLOGY (HUIZHOU) CO, LTD

"B", followed by two alphanumeric characters.

Low voltage fans, Models DB1206, DF1209, -1212, -2409, DH1204 followed by B or S, followed by two alphanumeric characters.



Marking: Company name or trademark **TOP MOTOR**, model designation and Recognized Component Mark for Canada,



Last Updated on 2008-02-18

[Questions?](#)

[Notice of Disclaimer](#)

[Page Top](#)

[Copyright © 2009 Underwriters Laboratories Inc.®](#)

The appearance of a company's name or product in this database does not in itself assure that products so identified have been manufactured under UL's Follow-Up Service. Only those products bearing the UL Mark should be considered to be Listed and covered under UL's Follow-Up Service. Always look for the Mark on the product.

UL permits the reproduction of the material contained in the Online Certification Directory subject to the following conditions: 1. The Guide Information, Designs and/or Listings (files) must be presented in their entirety and in a non-misleading manner, without any manipulation of the data (or drawings). 2. The statement "Reprinted from the Online Certifications Directory with permission from Underwriters Laboratories Inc." must appear adjacent to the extracted material. In addition, the reprinted material must include a copyright notice in the following format: "Copyright © 2009 Underwriters Laboratories Inc.®"

An independent organization working for a safer world with integrity, precision and knowledge.





DYNATRON CORPORATION

TOP MOTOR TECHNOLOGY (HUIZHOU) CO, LTD

6.5. Electrical Specifications for pwm production

USA Dynatron Corp.

Electrical Specifications for PWM production

Voltage

Fan operating voltage shall be within the range 12V \pm 1.2V.

Current

Peak fan current draw during start-up operation(with 13.2V applied,with fan operating in the free stream condition)shall not exceed 2.0 A.

Fan current spike during start-up operation(with 13.2V applied with fan operating in the free stream condition)shall be allowed to exceed 1.0 A for a duration of no greater than 1.0 sec.

Tachometer Output Signal

Fan shall provide tachometer output signal with the following characteristics:

- * Two pulses per revolution
- * Open-collector or open-drain type output
- * Motherboard will have a pull up to 12V, maximum 13.2V

PWM Control Input Signal

The following requirements are measured at the PWM(control) pin of the fan cable

connector:PWM Frequency:Target frequency 25kHz,

acceptable operational range 21 kHz to 28 Khz

Maximum voltage for logic low:VIL=0.8V

Absolute maximum current sourced:Imax=5mA(short circuit current)

Absolute maximum voltage level:Vmax=5.25V(open circuit voltage)

Fan Speed Control

1.1Maximum Fan Speed Requirements

The maximum fan speed shall be specified for the fan model by the vendor and correspond to 100% duty cycle PWM signal input.

1.2 Minimum Fan Speed Requirements

The vendor shall specify the minimum RPM and the corresponding PWM duty cycle. This specified minimum RPM shall be 30% of maximum RPM or less.The fan shall be able to start and run at this RPM. To allow a lower specified minimum RPM,it is acceptable to provide a higher PWM duty cycle to the fan motor for a short period of time for startup conditions.This pulse should not exceed 30% maximum RPM and should last no longer than 2 seconds.



DYNATRON CORPORATION

TOP MOTOR TECHNOLOGY (HUIZHOU) CO, LTD

USA Dynatron Corp.

1.3 Fan Speed Response PWM Control Input Signal

The PWM input shall be delivered to the fan through the control signal on Pin4. Fan speed response to this signal shall be a continuous and monotonic of the duty cycle of the signal, from 100% to the minimum specified RPM. The fan RPM (as a percentage of maximum RPM) should match the PWM duty cycle within $\pm 10\%$. If no control signal is present the fan shall operate at maximum RPM.

Figure 1 Fan speed Response to PWM Control input Signal

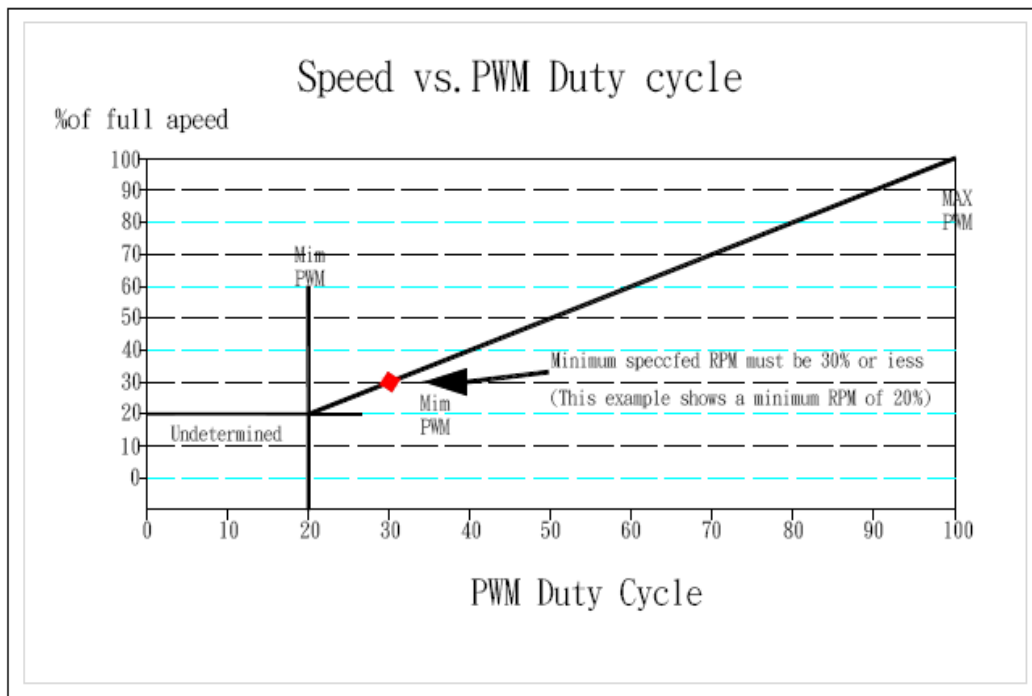

1.4 Operation Below Minimum RPM

For all duty cycles less than the minimum duty cycle, the RPM shall not be greater than the minimum RPM. The following graphs and definitions show three recommended solutions to handle PWM duty cycles that are less than the minimum operational PRM, as a percentage of maximum.

Reference resource by Intel's 4-wire PWM Fan controlled specification.



Certificate of Environment Protection

環保證明書

Document Number: RH-Q7-R0

Customer: 客戶名稱:	Company: Address: _____ Phone Number: _____ - _____ - _____
Issue Date: 發行日期:	09/30/2022
Product Model Number: 產品號碼:	Q7

Dynatron Corporation / Dynaeon Industrial Co., Ltd hereby declares and certifies that all components manufactured are RoHS, ROHS2 & ROHS3 compliant according to the definitions and restrictions given by the European Union's Restriction (Directive 2002/95/EC) (Directive 2011/65/EU) & (Directive (EU) 2015/863) as known as RoHS 3, on the restriction of the use of certain Hazardous Substances in the electrical and electronic equipment.

No exemptions are claimed in order for the part to be compliant with the RoHS directive.

Dynatron Corporation / 政久興業股份有限公司證明所有產品,零件 (包括附屬品,包裝類) 之環境管理物質完全符合 RoHS, WEEE, 及該環保標準之規定, 並承諾遵循以上之證明.

Dynatron Corporation / Dynaeon Industrial Co., Ltd.

Title (職務): _____ ASSISTANT-MANAGER / 副理 _____

Signature (簽字): _____

Date: 09/30/2022